

MITSUBISHI BASIC DIESEL GENERATOR SET TECHNICAL SPECIFICATION

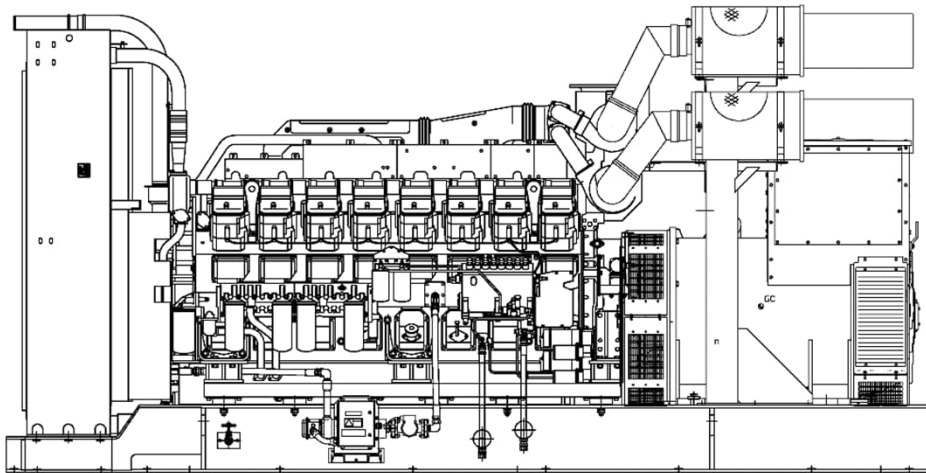

MG S1800R

1. GENERATOR SET OVERVIEW SPECIFICATION

This specification covers the indoor use MITSUBISHI diesel engine generator set and attached equipment.

		50Hz			
MGS Model		MGS1800R			
Voltage ¹	(V)	380			
Duty		Standby (ESP)	Critical Power (CP)	Prime (PRP)	Data Center Continuous Power (DCCP)
Rated Output ²	(KVA)	1675		1600	
	(kW)	1340		1280	
Engine model		S16R-PTAR			
Fuel Consumption ³ (liter/hr) (% load)	25%	116		113	
	50%	191		184	
	75%	267		256	
	100%	345		331	
Lub.Oil Consumption (100% Load)	(liter/hr)	1.39		1.33	
Generator	(MG-)	S7D			
Cooling system	(Type)	Closed looped circuit by integral radiator			
Dimensions					
Length	(mm)	5435	5435	5435	5435
Width	(mm)	2160	2160	2160	2160
Height	(mm)	2585	2635	2585	2635
Weight (Dry)	(kg)	12300	12500	12300	12500
	(Wet)	(kg)	12970	13170	12970

Note 1 For other voltage, please contact to Sales for confirmation

Note 2 Output at 40°C, 1000m ASL with fan

Note 3 Fuel consumption based on fuel density of 0.84 kg/l.
Fuel oil consumption may differ subject to site condition and specification of fuel.
Not guaranteed value.

1.1 ENVIRONMENT ETC.

MITSUBISHI generator sets are designed to meet following operating conditions

- a) Relative humidity : Max. 85%
- b) Ambient Temperature : 5°C ~ 40°C
- c) Altitude above sea level : 1000m

2. RATING DEFINITION

Duty	Overload	Yearly Average Load Factor	Yearly Operating hours	Allowable Average Load Factor for 24 Hours
Standby (ESP)	Not available	Maximum 70%	Maximum 500 hours	1. Maximum 80% 2. 100% in emergency
Prime (PRP)	+10% Overload	Maximum 70%	Unlimited	1. Maximum 80% 2. Overload operation ($\leq 110\%$) is limited to a maximum of 1 hour per 12 hours 3. Over 90% load operation limited to a maximum of 3 hours per 24 hours
Continuous (COP)	Not available	Maximum 100%	Unlimited	1. Maximum 100%
Critical Power (CP) ¹	Not available	Maximum 100%	Unlimited	1. Maximum 100%
Data Center Continuous Power (DCCP) ^{1, 2}	+10% Overload	Maximum 100%	Unlimited	1. Maximum 100% 2. Overload operation ($\leq 110\%$) is limited to a maximum of 1 hour per 12 hours

Note 1 UPTIME compliant: CP & DCCP rating meets the requirement of a Tier III and Tier IV data center site with no runtime limitation when the operation is loaded to 'N' demand for the engine generator set.

Note 2 +10% overload is not recognized by Uptime for Tier Certification.

3. DIESEL ENGINE

		50Hz			
		Standby (ESP)	Critical Power (CP)	Prime (PRP)	Data Center Continuous Power (DCCP)
Engine Model		S16R-PTAR 4 cycle, water cooled, turbocharged with after cooler			
Gross Engine Power (without fan basis)	(kWm)	1723		1553	
Fan loss	(kWm)	38		38	
Speed	(RPM)	1500		1500	
Brake mean effective Pressure	(MPa)	2.1		1.9	
Regenerative Absorption	(kW)	140			
No. of cylinder		16			
Bore / stroke	(mm)	170 / 180			
Total displacement	(liter)	65.37			
Compression ratio		14.0:1			
Piston Speed	(m/sec)	9.0			
Noise Level at 1m (Excluding: intake , exhaust & fan)	(dB(A))	111			
Governor	Type	Digital Electrical type			
Frequency regulation		G3 class			
Steady state Frequency band		±0.25%			
Heat rejection to coolant	(kW)	1062		951	
Heat rejection to exhaust	(kW)	1304		1186	
Heat rejection to atmosphere from engine	(kW)	128		115	

4. LUBRICATION SYSTEM

		50Hz			
		Standby (ESP)	Critical Power (CP)	Prime (PRP)	Data Center Continuous Power (DCCP)
Lubricating oil capacity	(liter)	230			
Lubrication system	Type	Forced lubricating by gear pump wet sump			
Lubrication Oil filter	Type	Paper element			
Lubrication Oil cooler	Type	Water cooled corrugated			

5. COOLING SYSTEM

		50Hz			
		Standby (ESP)	Critical Power (CP)	Prime (PRP)	Data Center Continuous Power (DCCP)
Coolant capacity without /with radiator	(liter)	170 / 383			
Coolant pump external resistance	(kgf/ cm ²)	0.35			
Coolant pump flow rate	(liter/ min)	1650			
Cooling fan airflow rate	(m ³ / min)	1950			
Cooling fan airflow restriction	(kPa)	0.1			
Ambient air temperature	(°C)	40			

6. INLET & EXHAUST SYSTEM

		50Hz			
		Standby (ESP)	Critical Power (CP)	Prime (PRP)	Data Center Continuous Power (DCCP)
Air cleaner	Type	Turbo filter	Paper element	Turbo filter	Paper element
Combustion air inlet flow rate	(m ³ / min)	145		130	
Exhaust flow rate	(m ³ / min)	385		345	
Max. exhaust gas temperature	(°C)	550			
Exhaust flange size (Internal diameter)		350A			
Allowable exhaust back pressure	(mm H2O)	600			

7. ELECTRICAL SYSTEM

		50Hz			
		Standby (ESP)	Critical Power (CP)	Prime (PRP)	Data Center Continuous Power (DCCP)
System voltage	(V)	24			
Starting system		Electric starting			
Starter motor capacity		7.5kW x 2			
Maximum allowable resistance of cranking circuit	(mΩ)	1.5			
Recommended minimum battery capacity	(Ah) At 5°C & above	400			
	(Ah) Below 5°C to -5°C	600			

8. GENERATOR

		50Hz			
		Standby (ESP)	Critical Power (CP)	Prime (PRP)	Data Center Continuous Power (DCCP)
Generator	Type	Brushless, self-excited, self-ventilated and rotating field			
Configuration		3Phase 4 Wire			
Protection		IP23			
Power factor		0.8 lagging			
No of poles		4 poles			
Insulation class		Class H			
Temperature rise		Class H Peak		Class H	
AVR	Type *1	DAVR			
Voltage regulation	Steady State *2	±0.25%			
	0 - 100% load	Maximum 1.0%			
Wave form distortion		5% (Non-Distorting Balanced Linear Load)			
Unbalance loading		Maximum 25%			
Negative phase sequence		Maximum 8%			
Overspeed		Maximum 125% of nominal speed			

*1 AVR is a standard for MG-HC5 and MG-KT series

*2 ±0.5% for AVR

9. GENERATOR CONTROL PANEL

		50Hz			
		Standby (ESP)	Critical Power (CP)	Prime (PRP)	Data Center Continuous Power (DCCP)
IP rating		IP 2X			
Power input		DC24V			
Sensing	Phase & Wire	3Phase 4 Wire			
	Frequency	50Hz			
LCD display parameters	Engine	Engine speed Engine Oil pressure Engine Coolant temperature Engine Oil temperature*1 Engine exhaust gas temperature*1 Engine crankcase internal pressure*1 Charging dynamo voltage Engine hour run DC battery voltage			
	Generator	Generator voltage (L-L, L-N AC) Generator frequency (Hz) Generator load (kW, kVA, kVAh) Generator accumulated load (kWh, kVAh, kVAh) Generator phase rotation Power factor Generator winding temperature (U,V,W)*1 Generator bearing temperature*1			
Protections	Engine	Engine underspeed warning and shutdown Engine overspeed warning and shutdown Engine coolant temperature high warning and shutdown Engine oil pressure low warning and shutdown Engine crankcase internal pressure high shutdown*1 DC battery voltage low and high warning Loss of magnetic pickup signal Mag. pickup open circuit Charge alternator failure warning Emergency stop Fail to start Fail to stop warning L.O filter clogged warning Oil pressure sender open circuit Oil temperature high warning and shutdown*1 Coolant level low warning*1 Exhaust temperature high warning*1			
	Generator	Generator undervoltage warning and shutdown Generator overvoltage warning and shutdown Generator underfrequency warning and shutdown Generator overfrequency warning and shutdown Generator overcurrent shutdown Negative phase sequence warning Winding temperature high warning(U,V,W)*1 Bearing temperature high warning*1 Electrical trip Generator power warning			
	Synchronising	Generator reverse power, shutdown*2 Breaker close failure, warning*2 Breaker open failure, warning *2 MSC Link Failure warning*2 Fail to synchronise warning*2			

	50Hz			
	Standby (ESP)	Critical Power (CP)	Prime (PRP)	Data Center Continuous Power (DCCP)
Auxiliary input	Remote start/stop Electrical trip CB close status (Generator closed auxiliary)			
Auxiliary output	CB open command (pulse) CB close command (pulse) Common shutdown Common warning kW overload System in auto mode Low speed detection Audible alarm (only when audible alarm is installed) Common electrical trip*1 Energize to stop*1 Fail to start alarm*1 Common alarm*1 Fail to start alarm*1 Over speed shutdown*1 Emergency stop*1 Oil pressure low shutdown*1 Coolant temperature high shutdown*1			
Status indicators	Generator at rest Generator available On load Generator stopping Cooling down Generator stopped Generator lock out Generator run indicator Remote start present indicator Generator ready indicator L.O filter clogged indicator Electrical trip indicator			
Controls	Voltage adjuster Frequency adjuster Emergency stop push button Key switch (STOP/RESET ACTIVE PANEL LOCK) Manual start button Manual stop/reset button Transfer to generator button (manual mode only) Open generator button (manual mode only) Alarm mute/Lamp test button Manual mode button Auto mode button Menu navigation buttons			

*1 Require expansion unit

*2 Applicable for synchronising controller only