

MITSUBISHI BASIC DIESEL GENERATOR SET TECHNICAL SPECIFICATION

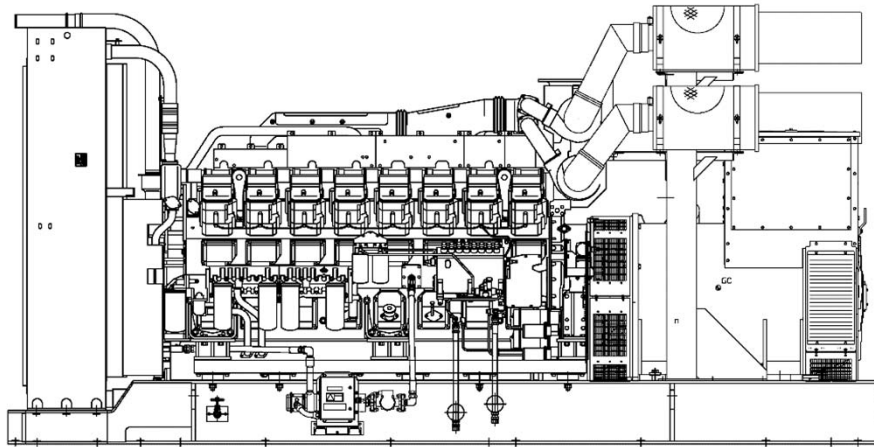

MGS3100R

1. Generator Set Overview Specification

This specification covers the indoor use MITSUBISHI diesel engine generator set and attached equipment.

		50Hz			
MGS Model		MGS3100R			
Voltage ¹	(V)	380			
Duty		Standby (ESP)	Critical Power (CP)	Prime (PRP)	Data Center Continuous Power (DCCP)
Rated Output ²	(KVA)	3025		2750	
	(kW)	2420		2200	
Engine model		S16R2-PTAWT-CR			
Fuel Consumption ³ (liter/hr) (% load)	25%	221		204	
	50%	382		349	
	75%	550		500	
	100%	642		618	
Lub.Oil Consumption (100% Load)	(liter/hr)	2.54		2.11	
Generator	(MG-)	L53M95			
Cooling system	(Type)	Closed looped circuit by integral radiator			
Dimensions					
Length	(mm)	6905	6905	6905	6905
Width	(mm)	2820	2820	2820	2820
Height	(mm)	3170	3170	3170	3170
Weight (Dry)	(kg)	21600	21900	21600	21900
	(Wet)	(kg)	22700	23000	22700

Note 1 For other voltage, please contact to Sales for confirmation

Note 2 Output at 40°C, 1000m ASL with fan

Note 3 Fuel consumption based on fuel density of 0.84 g/l.

Fuel oil consumption may differ subject to site condition and specification of fuel.
Not guaranteed value.

1.1 ENVIRONMENT ETC.

MITSUBISHI generator sets are designed to meet following operating conditions

- a) Relative humidity : Max. 85%
- b) Ambient Temperature : 5°C ~ 40°C
- c) Altitude above sea level : 1000m

2. Rating Definition

Duty	Overload	Yearly Average Load Factor	Yearly Operating hours	Allowable Average Load Factor for 24 Hours
Standby (ESP)	Not available	Maximum 70%	Maximum 500 hours	1. Maximum 80% 2. 100% in emergency
Prime (PRP)	+10% Overload	Maximum 70%	Unlimited	1. Maximum 80% 2. Overload operation ($\leq 110\%$) is limited to a maximum of 1 hour per 12 hours 3. Over 90% load operation limited to a maximum of 3 hours per 24 hours
Continuous (COP)	Not available	Maximum 100%	Unlimited	1. Maximum 100%
Critical Power (CP) ¹	Not available	Maximum 100%	Unlimited	1. Maximum 100%
Data Center Continuous Power (DCCP) ^{1, 2}	+10% Overload	Maximum 100%	Unlimited	1. Maximum 100% 2. Overload operation ($\leq 110\%$) is limited to a maximum of 1 hour per 12 hours

Note 1 UPTIME compliant: This DCCP rating meets the requirement of Tier III and Tier IV data center site with no runtime limitation when the operation is loaded to 'N' demand for the engine generator set.

Note 2 DCCP rating does not have +10% overload defined in ISO8528-1:2018

3. DIESEL ENGINE

		50Hz			
		Standby (ESP)	Critical Power (CP)	Prime (PRP)	Data Center Continuous Power (DCCP)
Engine Model		S16R2-PTAWT-CR 4 cycle, water cooled, turbocharged with aircooler			
Gross Engine Power (without fan basis)	(kWm)	2627		2396	
Fan loss	(kWm)	100		100	
Speed	(RPM)	1500		1500	
Brake mean effective Pressure	(MPa)	2.6		2.4	
Regenerative Absorption	(kW)	152			
No. of cylinder		16			
Bore / stroke	(mm)	170 / 220			
Total displacement	(liter)	79.9			
Compression ratio		13.8:1			
Piston Speed	(m/sec)	11.0			
Noise Level at 1m (Excluding: intake , exhaust & fan)	(dB(A))	112			
Governor	Type	LECM			
Frequency regulation		G3 class			
Steady state Frequency band		±0.25%			
Heat rejection to HT coolant	(kW)	1416		1279	
Heat rejection to LT coolant	(kW)	208		188	
Heat rejection to exhaust	(kW)	2249		2030	
Heat rejection to atmosphere from engine	(kW)	201		182	
Heat rejection to Fuel Oil	(kW)	13		12	

4. LUBRICATION SYSTEM

		50Hz			
		Standby (ESP)	Critical Power (CP)	Prime (PRP)	Data Center Continuous Power (DCCP)
Lubricating oil capacity	(liter)	290			
Lubrication system	Type	Forced lubricating by gear pump wet sump			
Lubrication Oil filter	Type	Paper element			
Lubrication Oil cooler	Type	Water cooled corrugated			

5. COOLING SYSTEM

		50Hz			
		Standby (ESP)	Critical Power (CP)	Prime (PRP)	Data Center Continuous Power (DCCP)
Coolant capacity without /with radiator	(liter)	37(LT), 212(HT) / 808			
Coolant pump external resistance	(kgf/cm ²)	0.35 (LT), 0.27 (HT)			
Coolant pump flow rate	(liter/min)	920 (LT), 1000 (HT)			
Cooling fan airflow rate	(m ³ / min)	2970			
Cooling fan airflow restriction	(kPa)	0.1			
Ambient air temperature	(°C)	40			

6. INLET & EXHAUST SYSTEM

		50Hz			
		Standby (ESP)	Critical Power (CP)	Prime (PRP)	Data Center Continuous Power (DCCP)
Air cleaner	Type	Turbo filter	Paper element	Turbo filter	Paper element
Combustion air inlet flow rate	(m ³ / min)	229		206	
Exhaust flow rate	(m ³ / min)	605		546	
Max. exhaust gas temperature	(°C)	550			
Exhaust flange size (Internal diameter)		400A			
Allowable exhaust back pressure	(mm H ₂ O)	602			

7. ELECTRICAL SYSTEM

		50Hz			
		Standby (ESP)	Critical Power (CP)	Prime (PRP)	Data Center Continuous Power (DCCP)
System voltage	(V)	24			
Starting system		Electric starting			
Starter motor capacity		7.5kW x 2			
Maximum allowable resistance of cranking circuit	(mΩ)	1.5			
Recommended minimum battery capacity	(Ah) At 5°C & above	400			
	(Ah) Below 5°C to -5°C	600			

8. GENERATOR

		50Hz			
		Standby (ESP)	Critical Power (CP)	Prime (PRP)	Data Center Continuous Power (DCCP)
Generator	Type	Brushless, self-excited, self-ventilated and rotating field			
Configuration		3Phase 4 Wire			
Protection		IP23			
Power factor		0.8 lagging			
No of poles		4 poles			
Insulation class		Class H			
Temperature rise		Class H Peak		Class H	
AVR	Type *1	DAVR			
Voltage regulation	Steady State *2	±0.25%			
	0 - 100% load	Maximum 1.0%			
Wave form distortion		5% (Non-Distorting Balanced Linear Load)			
Unbalance loading		Maximum 25%			
Negative phase sequence		Maximum 8%			
Overspeed		Maximum 125% of nominal speed			

*1 AVR is a standard for MG-HC5 and MG-KT series

*2 ±0.5% for AVR

9. GENERATOR CONTROL PANEL

		50Hz				
		Standby (ESP)	Critical Power (CP)	Prime (PRP)	Data Center Continuous Power (DCCP)	
IP rating		IP 2X				
Power input		DC24V				
Sensing	Phase & Wire	3Phase 4 Wire				
	Frequency	50 / 60Hz				
LCD display parameters	Engine	Engine speed Engine Oil pressure Engine Coolant temperature Engine Oil temperature*1 Engine exhaust gas temperature*1		Engine crankcase internal pressure*1 Charging dynamo voltage Engine hour run DC battery voltage		
	Generator	Generator voltage (L-L, L-N AC) Generator frequency (Hz) Generator load (kW, kVA, kVAh) Generator accumulated load (kWh, kVAh, kVAh)		Generator phase rotation Power factor Generator winding temperature (U,V,W)*1 Generator bearing temperature*1		
Protections	Engine	Engine underspeed warning and shutdown Engine overspeed warning and shutdown Engine coolant temperature high warning and shutdown Engine oil pressure low warning and shutdown Engine crankcase internal pressure high warning and shutdown*1 DC battery voltage low and high warning Loss of magnetic pickup signal Mag. pickup open circuit Charge alternator failure warning Fail to start warning Fail to start shutdown Fail to stop warning L.O filter clogged warning Oil pressure sender open circuit Oil temperature high warning and shutdown*1 Coolant level low warning*1 Exhaust temperature high warning*1 ECU battery voltage low and high warning Boost pressure low and high warning HT coolant temperature high warning and shutdown Rail pressure R and L high warning and shutdown Main ECU fault warning and shutdown Main ECU temperature high warning and shutdown HPP ECU fault warning and shutdown HPP ECU temperature high warning and shutdown Gen controller CAN fault Service tool CAN fault		ECU CAN network error warning Rail pressure R and L low warning and fault 1 shutdown Injector 01-16 open and short circuit warning Multiple injectors short circuit shutdown Boost press. sender fault shutdown HT coolant temperature sender fault shutdown Exhaust gas temperature sender fault warning Rail pressure R and L sender fault shutdown and fault 2 warning Oil pressure sender fault shutdown Oil temperature sender fault shutdown Main ECU temperature fault warning Main speed sender fault shutdown Main phase sender fault warning HPP speed sender fault shutdown HPP phase sender fault warning Fuel temperature sender fault warning HPP R and L delivery low and high warning HPP R1-R3, L1-L3 open circuit warning Crankcase pressure sender fault warning Fuel pre filter In and Out pressure sender fault warning R and L fuel main filter out pressure sender fault warning Fuel pre filter clogged warning R and L fuel main filter out pressure low warning Engine under speed on start warning Data Logger Fail Warning		

		50Hz			
		Standby (ESP)	Critical Power (CP)	Prime (PRP)	Data Center Continuous Power (DCCP)
Protections	Generator	Generator undervoltage warning and shutdown Generator overvoltage warning and shutdown Generator underfrequency warning and shutdown Generator overfrequency warning and shutdown Generator overcurrent shutdown Negative phase sequence warning Winding temperature high warning(U,V,W)*1 Bearing temperature high warning*1 Electrical trip Generator power warning AVR fault warning Maintenance run Inhibit on load shutdown ECU Data Fail Warning			
	Synchronising	Generator reverse power, shutdown*2 Breaker close failure, warning*2 Breaker open failure, warning *2 MSC Link Failure warning*2 Fail to synchronise warning*2			
Auxiliary input		Remote start/stop Electrical trip CB close status (Generator closed auxiliary)			
Auxiliary Output		CB open command (pulse) CB close command (pulse) Common shutdown Common warning kW overload System in auto mode Low speed detection Audible alarm (only when audible alarm is installed) Common electrical trip*1 Energize to stop*1 Fail to start alarm*1 Common alarm*1 Fail to start alarm*1 Over speed shutdown*1 Emergency stop*1 Oil pressure low shutdown*1 Coolant temperature high shutdown*1			

	50Hz			
	Standby (ESP)	Critical Power (CP)	Prime (PRP)	Data Center Continuous Power (DCCP)
Status indicators	Generator at rest Generator available On load Generator stopping Cooling down Generator stopped Generator lock out Generator run indicator Remote start present indicator Generator ready indicator L.O filter clogged indicator Electrical trip indicator			
Controls	Voltage adjuster Frequency adjuster Emergency stop push button Key switch (STOP/RESET ACTIVE PANEL LOCK) Manual start button Manual stop/reset button Transfer to generator button (manual mode only) Open generator button (manual mode only) Alarm mute/Lamp test button Manual mode button Auto mode button Menu navigation buttons			

*1 Require expansion unit

*2 Applicable for synchronising controller only