

MITSUBISHI BASIC DIESEL GENERATOR SET TECHNICAL SPECIFICATION

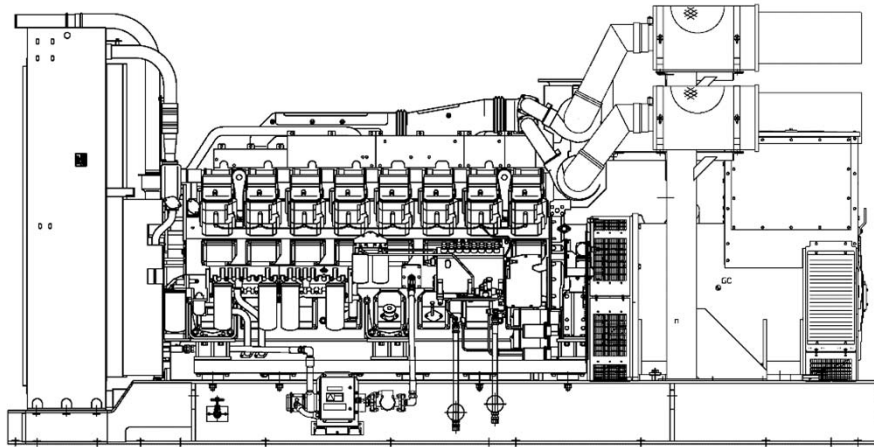

MGS0600R

1. Generator Set Overview Specification

This specification covers the indoor use MITSUBISHI diesel engine generator set and attached equipment.

		50Hz			
MGS Model		MGS0600R			
Voltage ¹	(V)	380			
Duty		Standby (ESP)	Critical Power (CP)	Prime (PRP)	Data Center Continuous Power (DCCP)
Rated Output ²	(KVA)	555		505	
	(kW)	444		404	
Engine model		S6A3-PTAA			
Fuel Consumption ³ (liter/hr) (% load)	25%	40		37	
	50%	52		60	
	75%	91		83	
	100%	120		109	
Lub.Oil Consumption (100% Load)	(liter/hr)	0.45		0.41	
Generator	(MG-)	HC5E			
Cooling system	(Type)	Closed looped circuit by integral radiator			
Dimensions					
Length	(mm)	3685	3685	3685	3685
Width	(mm)	1680	1680	1680	1680
Height	(mm)	1905	1905	1905	1905
Weight (Dry)	(kg)	4500	4600	4500	4600
	(Wet)	(kg)	4710	4810	4710

Note 1 For other voltage, please contact to Sales for confirmation

Note 2 Output at 40°C, 1000m ASL with fan

Note 3 Fuel consumption based on fuel density of 0.84 g/l.

Fuel oil consumption may differ subject to site condition and specification of fuel.
Not guaranteed value.

1.1 ENVIRONMENT ETC.

MITSUBISHI generator sets are designed to meet following operating conditions

- Relative humidity : Max. 85%
- Ambient Temperature : 5°C ~ 40°C
- Altitude above sea level : 1000m

2. Rating Definition

Duty	Overload	Yearly Average Load Factor	Yearly Operating hours	Allowable Average Load Factor for 24 Hours
Standby (ESP)	Not available	Maximum 70%	Maximum 500 hours	1. Maximum 80% 2. 100% in emergency
Prime (PRP)	+10% Overload	Maximum 70%	Unlimited	1. Maximum 80% 2. Overload operation ($\leq 110\%$) is limited to a maximum of 1 hour per 12 hours 3. Over 90% load operation limited to a maximum of 3 hours per 24 hours
Continuous (COP)	Not available	Maximum 100%	Unlimited	1. Maximum 100%
Critical Power (CP) ¹	Not available	Maximum 100%	Unlimited	1. Maximum 100%
Data Center Continuous Power (DCCP) ^{1, 2}	+10% Overload	Maximum 100%	Unlimited	1. Maximum 100% 2. Overload operation ($\leq 110\%$) is limited to a maximum of 1 hour per 12 hours

Note 1 UPTIME compliant: This DCCP rating meets the requirement of Tier III and Tier IV data center site with no runtime limitation when the operation is loaded to 'N' demand for the engine generator set.

Note 2 DCCP rating does not have +10% overload defined in ISO8528-1:2018

3. DIESEL ENGINE

		50Hz			
		Standby (ESP)	Critical Power (CP)	Prime (PRP)	Data Center Continuous Power (DCCP)
Engine Model		S6AR-PTAA 4 cycle, water cooled, turbocharged with after cooler			
Gross Engine Power (without fan basis)	(kWm)	483		440	
Fan loss	(kWm)	10		10	
Speed	(RPM)	1500		1500	
Brake mean effective Pressure	(MPa)	2.1		1.9	
Regenerative Absorption	(kW)	40			
No. of cylinder		6			
Bore / stroke	(mm)	150 / 175			
Total displacement	(liter)	18.56			
Compression ratio		14.5:1			
Piston Speed	(m/sec)	8.8			
Noise Level at 1m (Excluding: intake , exhaust & fan)	(dB(A))	101			
Governor	Type	Digital Electrical type			
Frequency regulation		G3 class			
Steady state Frequency band		±0.25%			
Heat rejection to coolant	(kW)	163		147	
Heat rejection to air to air cooler	(kW)	151		136	
Heat rejection to exhaust	(kW)	419		372	
Heat rejection to atmosphere from engine	(kW)	38		34	

4. LUBRICATION SYSTEM

		50Hz			
		Standby (ESP)	Critical Power (CP)	Prime (PRP)	Data Center Continuous Power (DCCP)
Lubricating oil capacity	(liter)	80			
Lubrication system	Type	Forced lubricating by gear pump wet sump			
Lubrication Oil filter	Type	Paper element			
Lubrication Oil cooler	Type	Water cooled corrugated			

5. COOLING SYSTEM

		50Hz			
		Standby (ESP)	Critical Power (CP)	Prime (PRP)	Data Center Continuous Power (DCCP)
Coolant capacity without /with radiator	(liter)	40 / 115			
Coolant pump external resistance	(kgf/ cm ²)	0.35			
Coolant pump flow rate	(liter/ min)	460			
Cooling fan airflow rate	(m ³ / min)	431			
Cooling fan airflow restriction	(kPa)	0.1			
Ambient air temperature	(°C)	40			

6. INLET & EXHAUST SYSTEM

		50Hz			
		Standby (ESP)	Critical Power (CP)	Prime (PRP)	Data Center Continuous Power (DCCP)
Air cleaner	Type	Turbo filter	Paper element	Turbo filter	Paper element
Combustion air inlet flow rate	(m ³ / min)	43		39	
Exhaust flow rate	(m ³ / min)	113		102	
Max. exhaust gas temperature	(°C)	550			
Exhaust flange size (Internal diameter)		200A			
Allowable exhaust back pressure	(mm H2O)	600			

7. ELECTRICAL SYSTEM

		50Hz			
		Standby (ESP)	Critical Power (CP)	Prime (PRP)	Data Center Continuous Power (DCCP)
System voltage	(V)	24			
Starting system		Electric starting			
Starter motor capacity		6kW x 1			
Maximum allowable resistance of cranking circuit	(mΩ)	2.5			
Recommended minimum battery capacity	(Ah) At 5°C & above	200			
	(Ah) Below 5°C to -5°C	300			

8. GENERATOR

		50Hz			
		Standby (ESP)	Critical Power (CP)	Prime (PRP)	Data Center Continuous Power (DCCP)
Generator	Type	Brushless, self-excited, self-ventilated and rotating field			
Configuration		3Phase 4 Wire			
Protection		IP23			
Power factor		0.8 lagging			
No of poles		4 poles			
Insulation class		Class H			
Temperature rise		Class H Peak		Class H	
AVR	Type *1	DAVR			
Voltage regulation	Steady State *2	±0.25%			
	0 - 100% load	Maximum 1.0%			
Wave form distortion		5% (Non-Distorting Balanced Linear Load)			
Unbalance loading		Maximum 25%			
Negative phase sequence		Maximum 8%			
Overspeed		Maximum 125% of nominal speed			

*1 AVR is a standard for MG-HC5 and MG-KT series

*2 ±0.5% for AVR

9. GENERATOR CONTROL PANEL

		50Hz			
		Standby (ESP)	Critical Power (CP)	Prime (PRP)	Data Center Continuous Power (DCCP)
IP rating		IP 2X			
Power input		DC24V			
Sensing	Phase & Wire	3Phase 4 Wire			
	Frequency	50 / 60Hz			
LCD display parameters	Engine	Engine speed Engine Oil pressure Engine Coolant temperature Engine Oil temperature*1 Engine exhaust gas temperature*1 Engine crankcase internal pressure*1 Charging dynamo voltage Engine hour run DC battery voltage			
	Generator	Generator voltage (L-L, L-N AC) Generator frequency (Hz) Generator load (kW, kVA, kVA _r) Generator accumulated load (kWh, kVAh, kVA _r h) Generator phase rotation Power factor Generator winding temperature (U,V,W)*1 Generator bearing temperature*1			
Protections	Engine	Engine underspeed warning and shutdown Engine overspeed warning and shutdown Engine coolant temperature high warning and shutdown Engine oil pressure low warning and shutdown Engine crankcase internal pressure high shutdown*1 DC battery voltage low and high warning Loss of magnetic pickup signal Mag. pickup open circuit Charge alternator failure warning Emergency stop Fail to start Fail to stop warning L.O filter clogged warning Oil pressure sender open circuit Oil temperature high warning and shutdown*1 Coolant level low warning*1 Exhaust temperature high warning*1			
	Generator	Generator undervoltage warning and shutdown Generator overvoltage warning and shutdown Generator underfrequency warning and shutdown Generator overfrequency warning and shutdown Generator overcurrent shutdown Negative phase sequence warning Winding temperature high warning(U,V,W)*1 Bearing temperature high warning*1 Electrical trip Generator power warning			
	Synchronising	Generator reverse power, shutdown*2 Breaker close failure, warning*2 Breaker open failure, warning *2 MSC Link Failure warning*2 Fail to synchronise warning*2			

	50Hz			
	Standby (ESP)	Critical Power (CP)	Prime (PRP)	Data Center Continuous Power (DCCP)
Auxiliary input	Remote start/stop Electrical trip CB close status (Generator closed auxiliary)			
Auxiliary output	CB open command (pulse) CB close command (pulse) Common shutdown Common warning kW overload System in auto mode Low speed detection Audible alarm (only when audible alarm is installed) Common electrical trip*1 Energize to stop*1 Fail to start alarm*1 Common alarm*1 Fail to start alarm*1 Over speed shutdown*1 Emergency stop*1 Oil pressure low shutdown*1 Coolant temperature high shutdown*1			
Status indicators	Generator at rest Generator available On load Generator stopping Cooling down Generator stopped Generator lock out Generator run indicator Remote start present indicator Generator ready indicator L.O filter clogged indicator Electrical trip indicator			
Controls	Voltage adjuster Frequency adjuster Emergency stop push button Key switch (STOP/RESET ACTIVE PANEL LOCK) Manual start button Manual stop/reset button Transfer to generator button (manual mode only) Open generator button (manual mode only) Alarm mute/Lamp test button Manual mode button Auto mode button Menu navigation buttons			

*1 Require expansion unit

*2 Applicable for synchronising controller only